

DENON

Hi-Fi Stereo Pre Amplifier

SERVICE MANUAL MODEL PRA-2000Z

For EUROPEAN MODEL

SOLID STATE
STEREO PRE AMPLIFIER

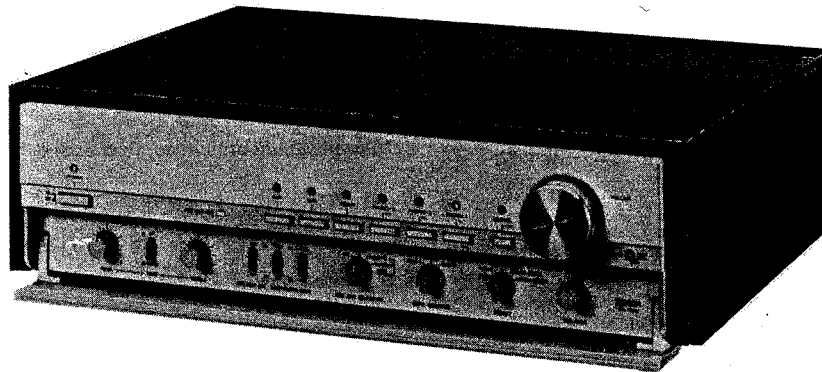

TABLE OF CONTENTS

SPECIFICATIONS	2
CONTROLS AND FUNCTIONS	3
CONNECTIONS	4
BLOCK DIAGRAM	5
TROUBLESHOOTING	6
METHOD OF ADJUSTMENTS	7, 8
SEMICONDUCTORS	9
PRINTED WIRING BOARD PATTERNS AND PARTS LIST	
SUX0035B POWER SUPPLY UNIT	9
AUX0029B CONTROL UNIT	10, 11
ETC0699B SERVO UNIT	11
EUX0016B EQ. & MC UNIT	12, 13
ETC0653B TAPE & FLAT UNIT	14
ETC0654B DIGITAL UNIT	15
CONNECTION DIAGRAM	16
WIRING DIAGRAM	17
EXPLODED VIEW OF CHASSIS AND CABINET & PARTS LIST	18

NIPPON COLUMBIA CO., LTD.

OCT. 1984

SPECIFICATIONS

EQUALIZER AMPLIFIER (Phono IN-REC OUT)

Input sensitivity/impedance:	*Phono-1 MC 0.1 mV/40 ohm Phono-2 MC 0.12 mV/100 ohm Phono-3 MM 2.5 mV/47 k ohm
Max. input level:	*Phono-1 MC 20 mV/1 kHz Phono-2 MC 24 mV/1 kHz Phono-3 MM 500 mV/1 kHz
Max. output/rated output:	30 V/150 mV
Total harmonic distortion:	*Less than 0.001% 1 kHz 20 V Out (Phono-1) Less than 0.0015% 20 Hz – 20 kHz 3 V Out (Phono-2, 3)
RIAA deviation:	*Phono-1 MC 20 Hz – 100 kHz ± 0.2 dB Phono-2 MC 20 Hz – 100 kHz ± 0.2 dB Phono-3 MM 10 Hz – 100 kHz ± 0.2 dB
SN ratio:	*Phono-1 MC 80 dB (0.25 mV input, "A"-weighting) Phono-2 MC 75 dB (0.25 mV input, "A"-weighting) Phono-3 MC 90 dB ("A"-weighting)
Separation:	80 dB (20 Hz – 1 kHz), 70 dB (20 kHz)
	* includes MC transformer characteristics.

FLAT AMPLIFIER (AUX IN – PRE OUT)

Input sensitivity/impedance:	Tuner, DAD, AUX, PB-1, PB-2 150 mV/47 k ohms
Max. output/rated output:	12 V/1.0 V
Total harmonic distortion:	Less than 0.0015% (20 Hz – 20 kHz, 4 V output)

Frequency response:	1 Hz – 300 kHz $+0, -3$ dB (10 Hz – 100 kHz $+0, -0.3$ dB)
Signal to noise ratio:	105 dB (A-weighting)
Separation:	VR max, 100 dB (20 Hz) 75 dB (1 kHz) 65 dB (20 kHz)
Muting:	-20 dB (LED indication)
PRE out off muting:	$-\infty$ dB (LED indication)
Filters:	High filter 7 kHz -6 dB/oct Low filter 16 Hz -6 dB/oct (subsonic filter)
Tone control:	Treble 10 kHz ± 8 dB Bass 100 Hz ± 8 dB

GENERAL**AC Outlets (For U.S.A., Canada, Singapore and Hong Kong:**

AC Outlets (For U.S.A., Canada, Singapore and Hong Kong:	2 AC outlets (700W total) unswitched 3 AC outlets (210W total) switched
Power supply:	AC 120 V, 60 Hz (for U.S.A. & Canada) AC 220 V, 50 Hz (for Europe) AC 240 V, 50 Hz (for UK & Australia)
Power consumption	70 W (for U.S.A., Europe)
Dimensions:	462 (W) x 145 (H) x 385 (D) mm (including control knobs and feet)
Weight:	10.6 kg

* Specifications are subject to change without notice.

NOTE: The following codes correspond to the appropriate models.
E1 for Asia, E2 for Europe, E3 for U.S.A., EA for Australia, EC for Canada and EF for France.
This Service Manual is prepared based on E2.

CONTROLS AND FUNCTIONS

• FRONT PANEL

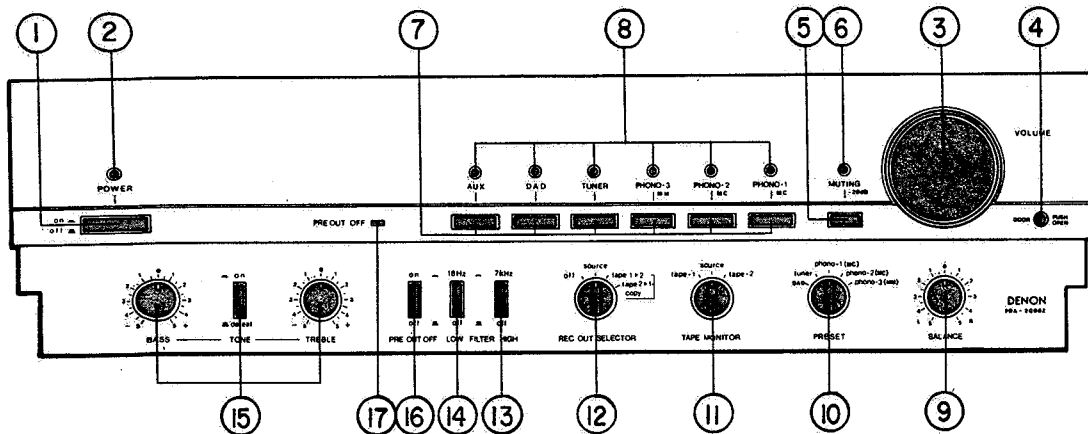

Fig. 1

- | | |
|--|---|
| <ul style="list-style-type: none"> ① POWER (Power Switch) ② POWER INDICATOR (Power Indicator) ③ VOLUME (Sound Level Control) ④ PUSH DOOR OPEN (Knob for Opening Front Door) ⑤ MUTING (Muting Switch) ⑥ MUTING INDICATOR ⑦ INPUT SELECTOR (Input Selector Switches) <ul style="list-style-type: none"> • PHONO-1 • PHONO-2 • PHONO-3 MC MC MM • TUNER • DAD-AUX ⑧ INPUT SELECTOR INDICATOR (Input Selector Indication) ⑨ BALANCE (Balance Control) | <ul style="list-style-type: none"> ⑩ PRESET (Priority Position Selector Switch) ⑪ TAPE MONITOR (Tape Monitor Switch) <ul style="list-style-type: none"> • source • tape-1 • tape-2 ⑫ REC OUT SELECTOR (Rec Out Selector) <ul style="list-style-type: none"> • off • source • copy tape 1 ▶ 2 • copy tape 2 ▶ 1 ⑬ HIGH FILTER (High Cut Filter) ⑭ LOW FILTER (Low Cut Filter or Subsonic Filter) ⑮ TONE (Tone Control) <ul style="list-style-type: none"> • TONE • TREBLE • BASS ⑯ PREOUT OFF (Pre Out Off Switch) ⑰ PREOUT OFF INDICATOR |
|--|---|

• REAR PANEL

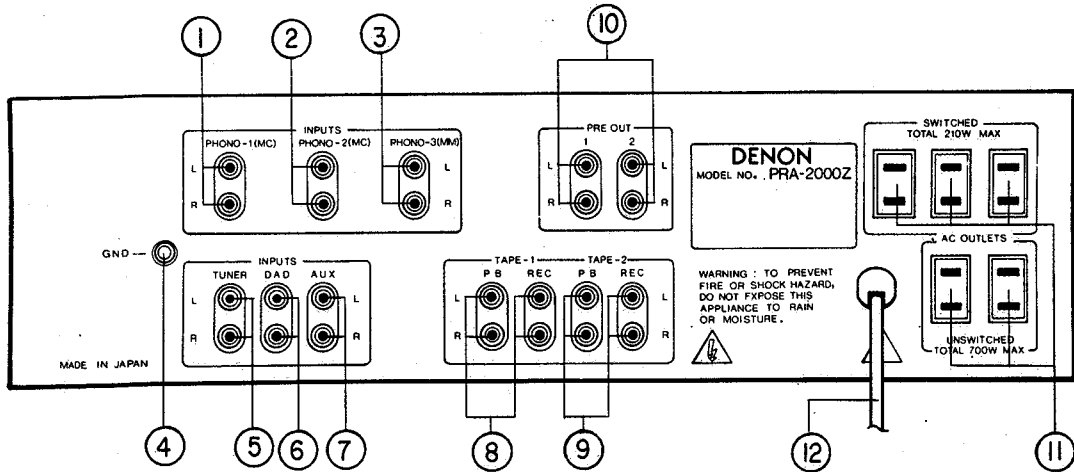

Fig. 2

- | | |
|--|--|
| <ul style="list-style-type: none"> ① PHONO-1 (Phono 1 Input Terminal) ② PHONO-2 (Phono 2 Input Terminal) ③ PHONO-3 (Phono 3 Input Terminal) ④ GND (Ground Terminal) ⑤ TUNER (Tuner Input Terminal) ⑥ DAD (Digital Audio Disk Input Terminal) ⑦ AUX (Auxiliary Input Terminal) | <ul style="list-style-type: none"> ⑧ ⑨ TAPE-1, 2 (Tape Recorder Record/Playback Terminals) ⑩ PREOUT (Preamplifier Output Terminal) ⑪ AC OUTLETS (AC Power Outlets) <ul style="list-style-type: none"> ... not included in systems for use in Europe. ⑫ POWER CORDS |
|--|--|

PRECAUTION

This unit is provided with a useful shorting pin to be used for PHONO INPUT terminal. Insert this pin into the PHONO INPUT terminal without connecting a player prevents the reproducing of noises. Be sure that this pin is only for input terminal jumper and never be used for the terminals of PRE OUT or TAPE REC. Failure to insert the pin into these terminals results in damaging the unit.

CONNECTION

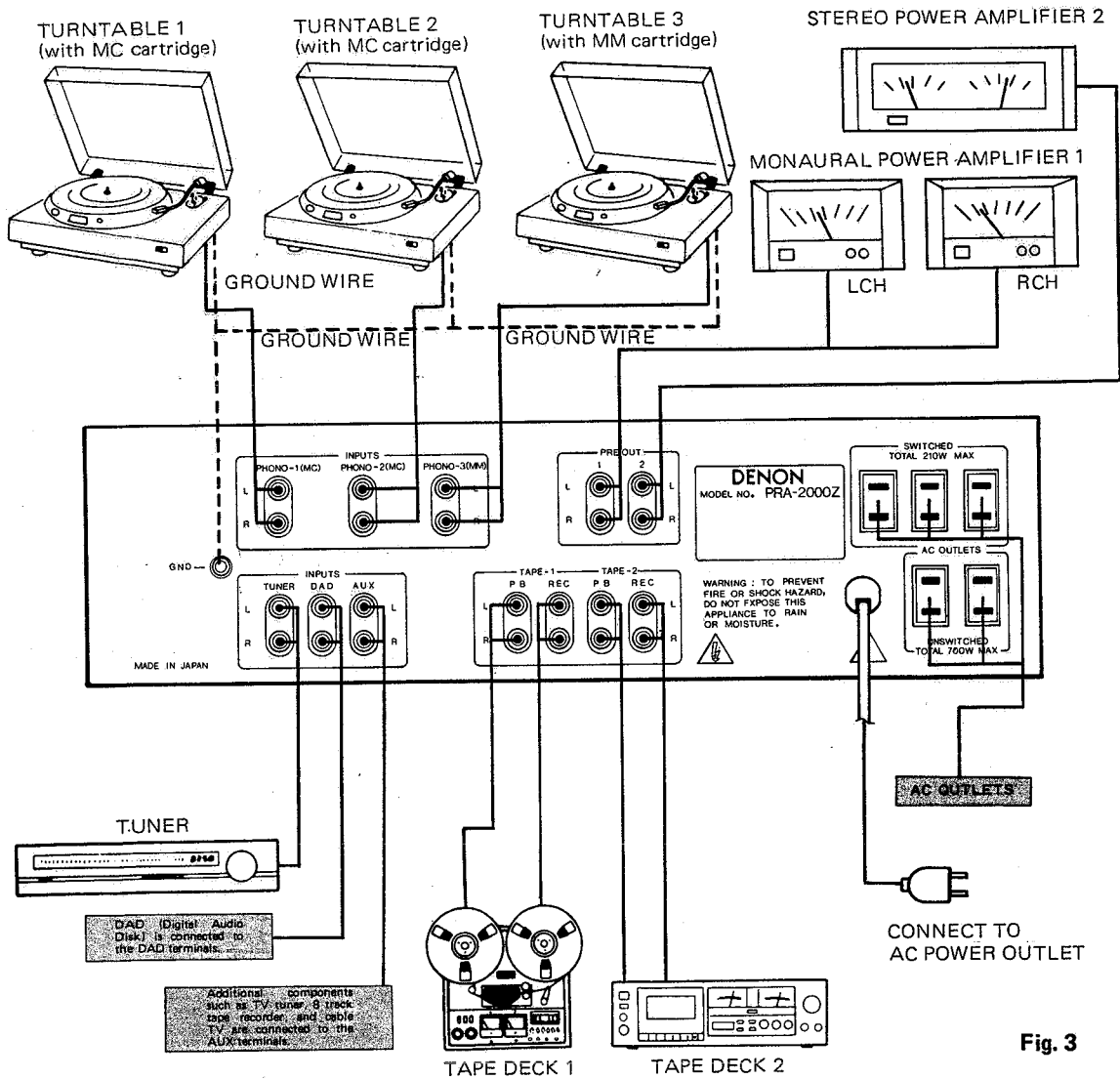

Fig. 3

CONNECTION PRECAUTIONS

- When making connections, make sure that the power is turned OFF.
- Make sure that the L output terminal of the turntable (or other audio equipment) is connected to the L input terminal. Check that the R output terminal of the turntable (or other audio equipment) is connected to the corresponding R input terminal.
- Make secure connections. If connections are not secure, noise or loss of sound output may occur.
- Power can be supplied to other components, but not other household appliances such as a hair dryer.
- Do not bundle pin plug cords with the power cords. Place pin plug cords away from power transformers supply since hum or noise may occur.

AC OUTLETS (not included in systems for use in Europe.)

For your convenience, the PRA-2000Z provides 5 AC OUTLETS (3 switched and 2 unswitched) on the rear panel.

SWITCHED (power consumption of up to 210W):

Switched power can be supplied.

UNSWITCHED (power consumption of up to 700W):

Unswitched power can be supplied, and is optimized for the DENON POA-3000Z power amplifier.

	Input sensitivity	Input impedance	Recommended cartridge type
PHONO-1 MC	100 μ V	40 ohm	MC
PHONO-2 MC	120 μ V	100 ohm	MC
PHONO-3 MM	2.5 mV	47 k ohm	MM

Table 1

BLOCK DIAGRAM

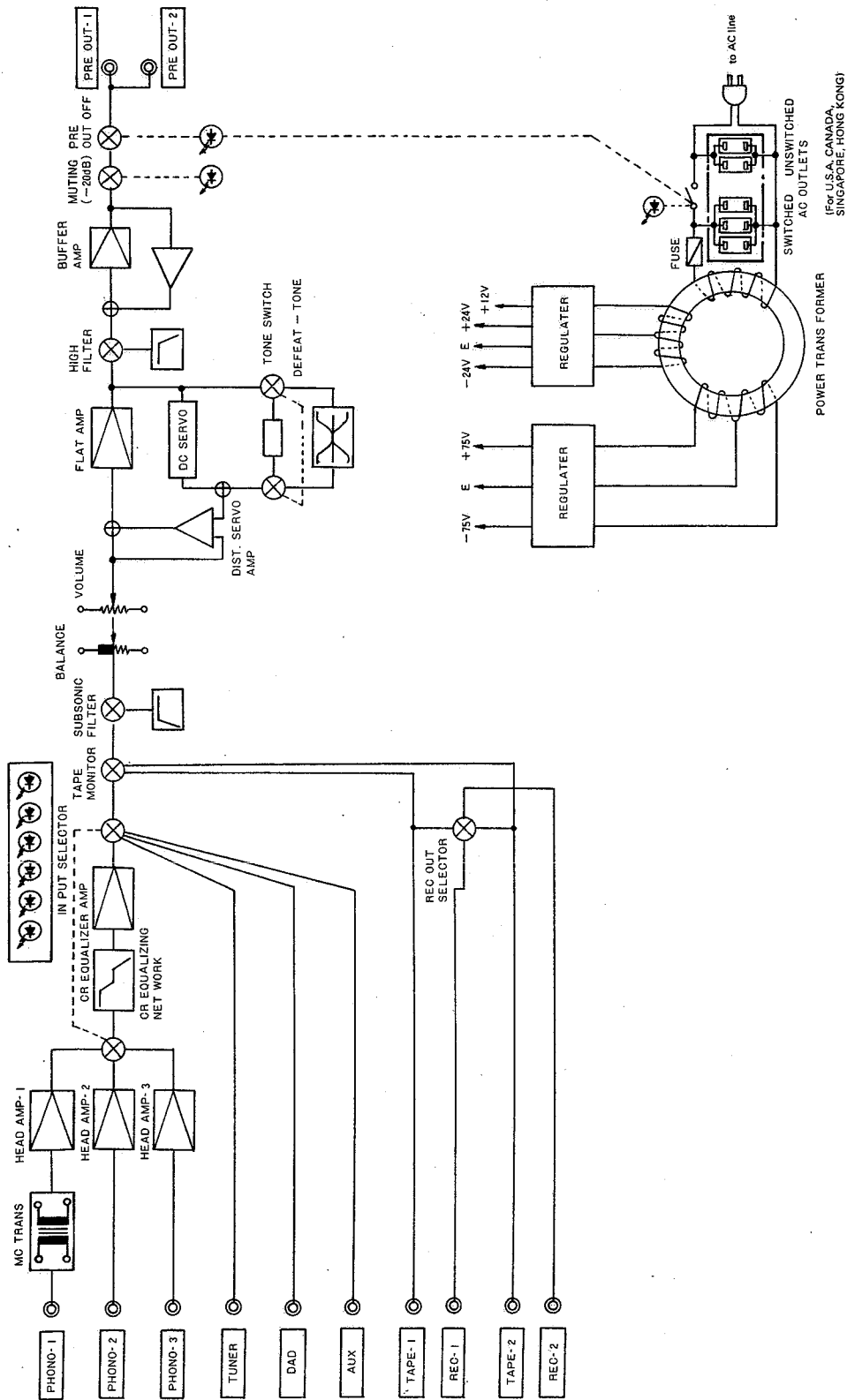

Fig. 4

TROUBLE SHOOTING

Before assuming a PRA-2000Z preamplifier fault, check the following:

1. Are all connections made properly?
2. Are operations correct?
3. Are speakers and turntables functioning normally?

When the PRA-2000Z is not functioning normally, check the following troubleshooting flowchart. This details the corrective action you can follow without having a service representative. If you have any doubts or questions, contact your nearest DENON dealer.

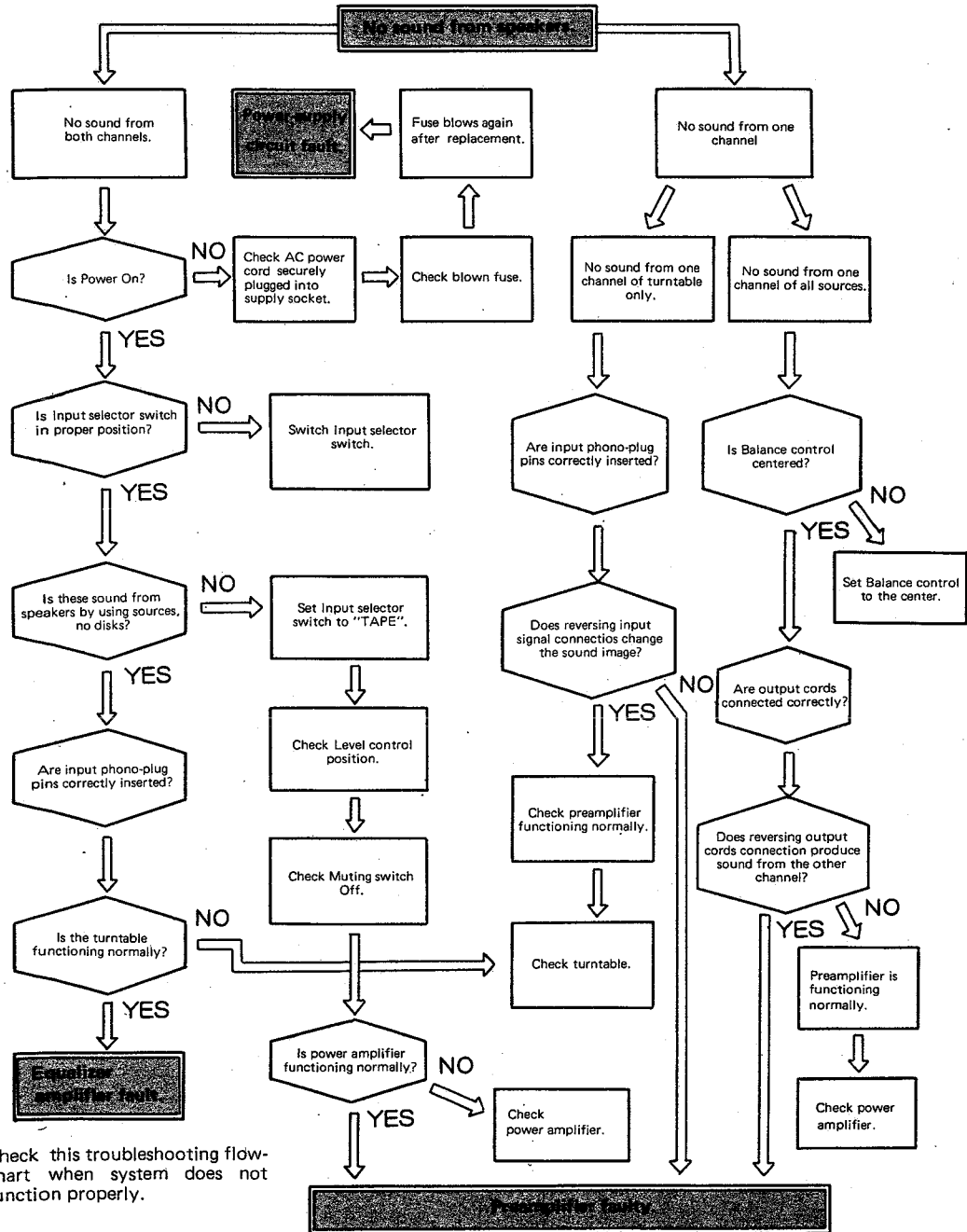

Fig. 5

METHOD OF ADJUSTMENTS

● Adjustment of Neutral Point Voltage

(1) EQ. AMP UNIT

- 1 Connect a digital voltmeter to the REC OUT 1 Lch (Rch) terminal on the rear panel.
- 2 Set the knobs on the front panel to the following positions.
 - VOLUME → Min (↶)
 - REC OUT SELECTOR → SOURCE
 - TAPE MONITOR → SOURCE
 - INPUT SELECTOR → PHONO-3 MM
- 3 Turn the unit power on (⏻).
- 4 Rotate the semi-fixed variable resistor VR1 (VR2) on the ETC0653 (TAPE & FLAT unit) and adjust voltage value on the meter to $0 \text{ mV} \pm 0.5 \text{ mV}$.

(2) FLAT AMP UNIT

- 1 Connect a digital voltmeter to the PRE OUT 1 Lch (Rch) terminal on the rear panel.
- 2 Set the knobs on the front panel to the following positions.
 - INPUT SELECTOR → TUNER
 - VOLUME → Min (↶)
- 3 Turn the unit power on (⏻).
- 4 Rotate the semi-fixed variable resistor VR1 (VR2) on the AUX0029B (CONTROL unit) and adjust viltage value on the meter to $0 \text{ mV} \pm 0.5 \text{ mV}$.

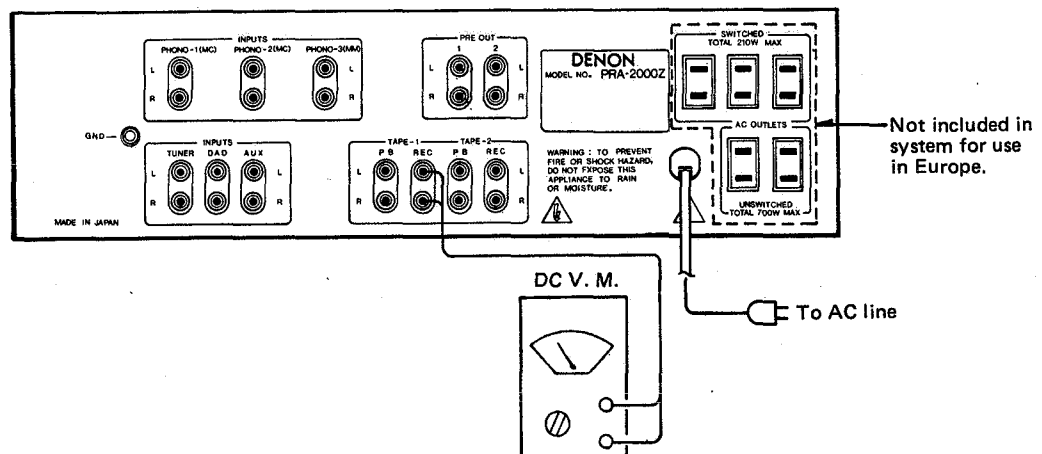

Fig. 6

ALIGNMENT POINTS (Component side)
• ETC0653B TAPE & FLAT UNIT

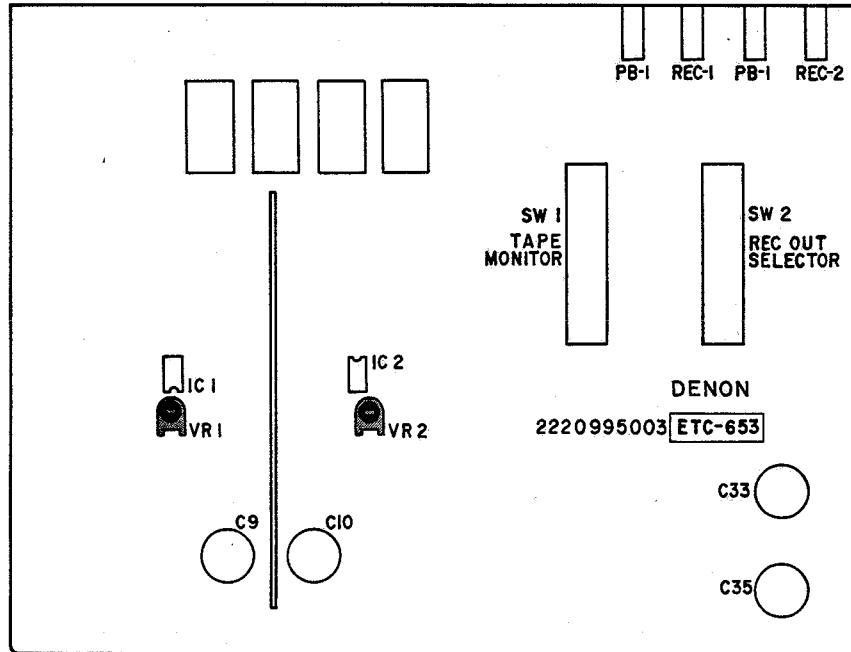

Fig. 7

• AUX0029B CONTROL UNIT

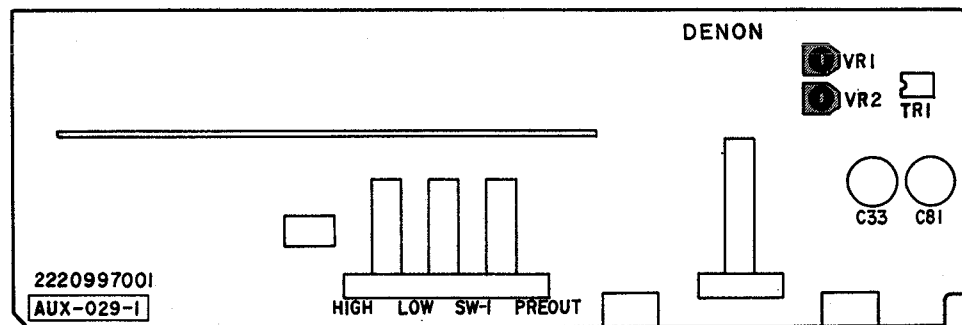
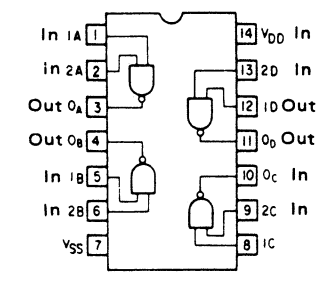
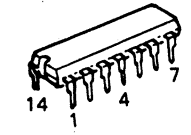

Fig. 8

SEMICONDUCTORS

• IC's

HD14011BP (Hitachi)



NJM4558D-D (JRC)

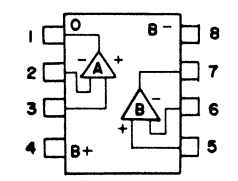
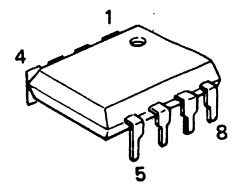

TC9135P (Toshiba)

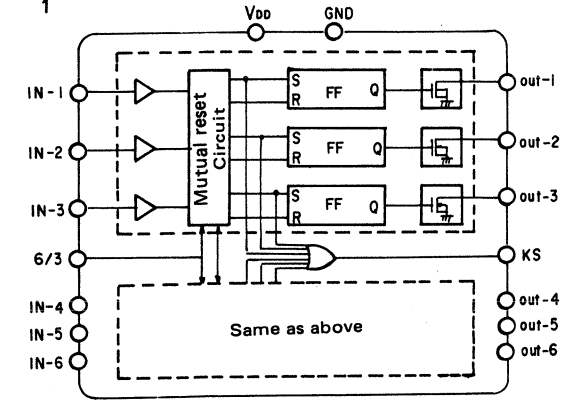
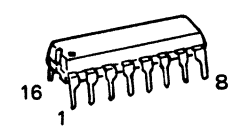

• Diode & LED

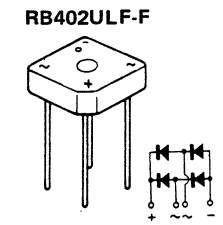
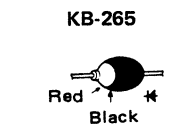
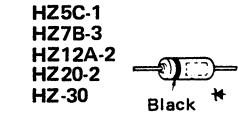
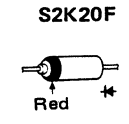
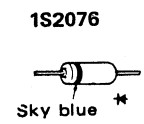

μPC741C(NEC)

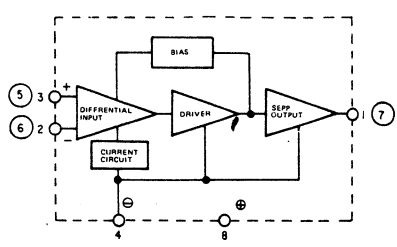
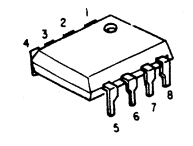

NJM78M24A (JRC)

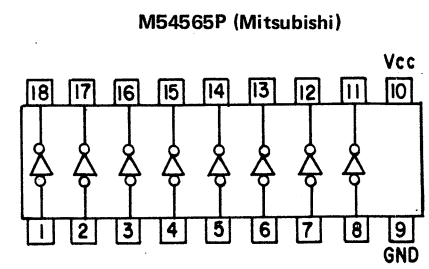
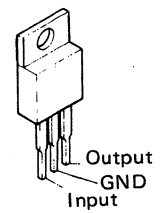

M54565P (Mitsubishi)

• Transistors and FET

- 2SA1145(O/Y)
- 2SC2705(O/Y)
- 2SA1015(Y)
- 2SA1815(Y)
- 2SC2878(A/B)
- 2SA1316(BL/GR)
- 2SC3329(GR/BL)
- 2SC2240

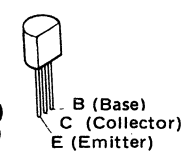

2SC1735(D)/(E)
2SA850(D)/(E)

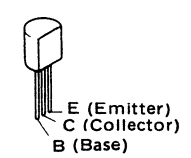

FET 2SK373(Y)
2SK381(C)/(D)

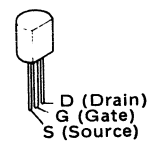

FET 2SK369(BL)/(GR)-C

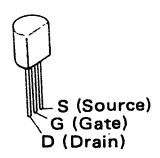

2SA1103(O)/(Y)
2SC2578(O/Y)

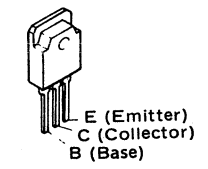

2SA968(Y)
2SC2238(Y)
2SD880(Y)/(GR)
2SD834(Y)
2SC1626(Y)

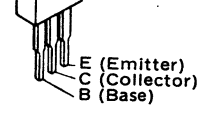

FET 2SK270A(BL)/(V)

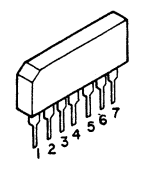

UB-152LFA

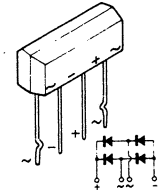

TLG206(Green)
TLY206(Yellow)

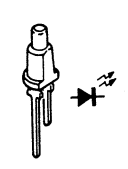

AA-5541K (Orange)

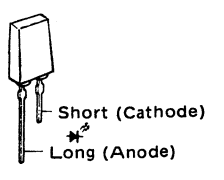

**PRINTED WIRING BOARD PATTERNS AND PARTS LIST
SUX0035B POWER SUPPLY UNIT**

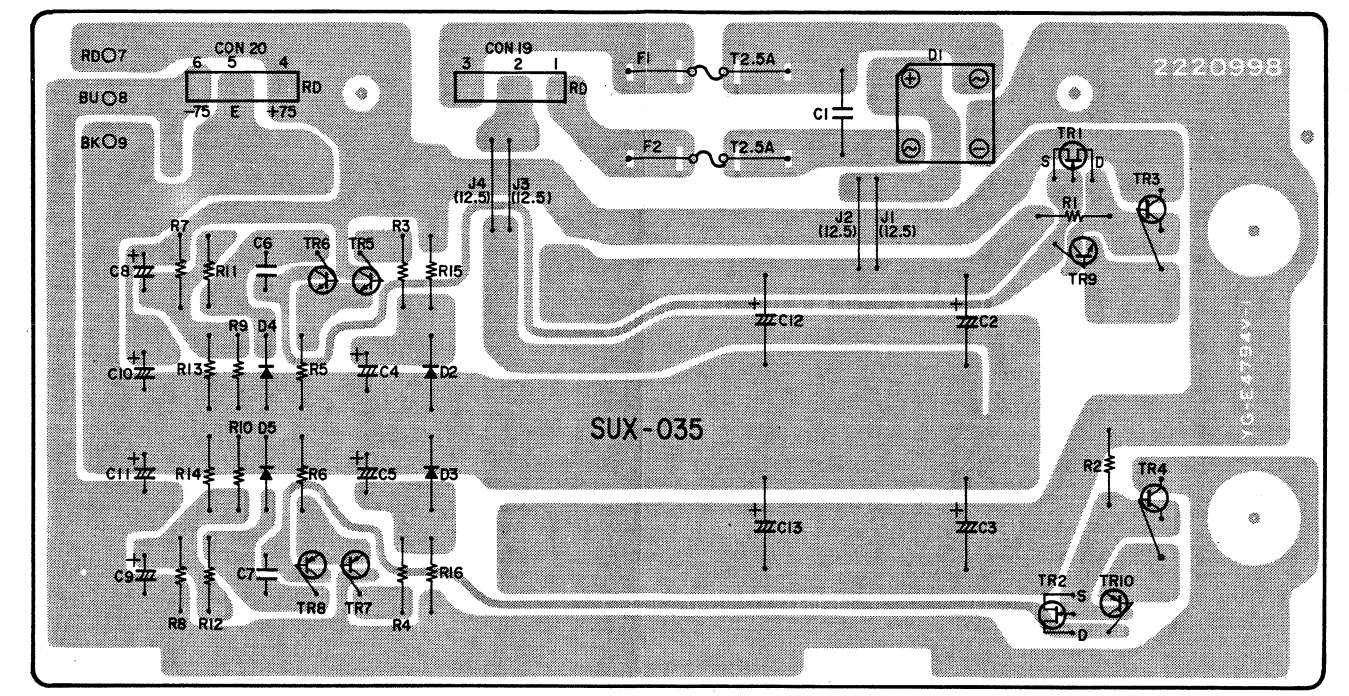

SUX0035B POWER SUPPLY UNIT PARTS LIST

Ref. No.	Part No.	Part Name & Descriptions
SEMICONDUCTORS		
TR001, 002	2750042002	2SK373(Y) FET
TR003	2730234021	2SC2578(O)/(Y) TRANSISTOR
TR004	2710132020	2SA1103(O)/(Y) TRANSISTOR
TR005, 006	2730281003	2SC2705(O/Y) TRANSISTOR
TR007, 008	2710168007	2SA1145(O/Y) TRANSISTOR
TR009	2730163040	2SC1735(D)/(E) TRANSISTOR
TR010	2710072005	2SA850(D)/(E) TRANSISTOR
D001	2760349009	RB402ULF-F DIODE
D002, 003	2760254000	HZ7B-3 ZENER
D004, 005	2760049008	1S2076 DIODE
RESISTORS		
R003, 004	2412321003	1 kohm ±5% 1/4W CARBON (NB)
R005, 006	2412321090	680 ohm ±5% 1/4W CARBON (NB)
R007, 008	2412320046	150 kohm ±2% 1/4W CARBON
R009, 010	2412318032	18 kohm ±2% 1/4W CARBON
R011, 012	2412321003	1 kohm ±5% 1/4W CARBON (NB)
R015, 016	2412128002	33 kohm ±5% 1/4W CARBON

Ref. No.	Part No.	Parts Name & Descriptions
CAPACITORS		
C001	2561016007	0.068μF ±10% 400V METALIZED
C002, 003	2544181027	1000μF ±20% 100V ELECTROLYTIC
C004, 005	2544060009	10μF 100V ELECTROLYTIC
C006, 007	2554121006	100pF ±5% 50V PLASTIC FILM
C008, 009	2544060025	1μF 100V ELECTROLYTIC
C010, 011	2544060009	10μF 100V ELECTROLYTIC
C012, 013	2544181027	1000μF ±20% 100V ELECTROLYTIC
OTHER PARTS		
AF001, 002	2220998000	P.W. BOARD
	2090008117	JUMPER WIRE P=12.5mm USED 6
AF001, 002	2061035067	FUSE 2.5A TLC USED 2
	2020014003	FUSE CLIP USED 4
	2050122033	3P CONNECTOR PIN ASS'Y USED 2
	4170170002	RADIATOR
	4150234007	INSULATING SHEET USED 2
	4700012022	PAN SCREW 3x12 WITH W.SW USED 2
	SC-06272	FIX. SCREW USED 2
	2034166028	3P CONNECTOR CORD

AUX0029B CONTROL UNIT

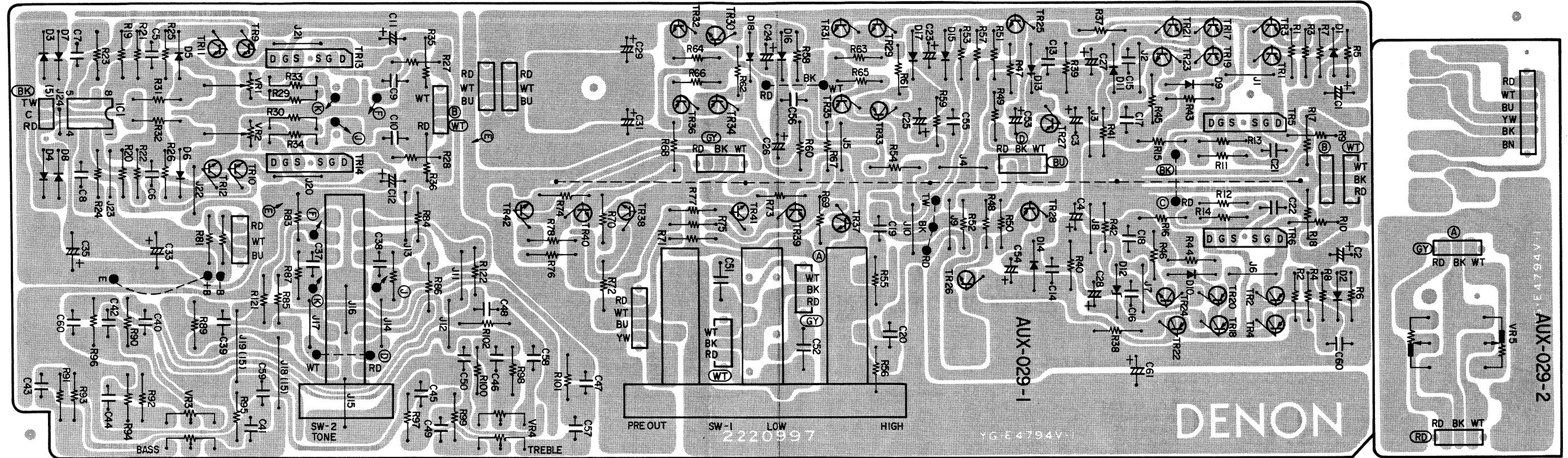

AUX0029B CONTROL UNIT PARTS LIST

Ref. No.	Part No.	Part Name & Descriptions	
SEMICONDUCTORS			
IC001	2650030004	NJM4558D-D (JRC)	IC
TR001	2710102005	2SA1015(Y)	TRANSISTOR
~004			
TR005, 006	2750036021	2SK270A(BL)/(V)	FET
TR009	2730198015	2SC1815(BL)	TRANSISTOR
~012			
TR013, 014	2750036021	2SK270A(BL)/(V)	FET
TR017	2710102005	2SA1015(Y)	TRANSISTOR
~022			
TR023	2730198002	2SC1815(Y)	TRANSISTOR
~026			
TR027, 028	2710102005	2SA1015(Y)	TRANSISTOR
TR029, 030	2730198002	2SC1815(Y)	TRANSISTOR
TR031, 032	2730163040	2SC1735(D)/(E)	TRANSISTOR
TR033, 034	2710102005	2SA1015(Y)	TRANSISTOR
TR035, 036	2710072025	2SA850(D)/(E)	TRANSISTOR
TR037, 038	2730253015	2SC2875(A/B)	TRANSISTOR
TR039, 040	2730253015	2SC2878(A)/(B)	TRANSISTOR

Ref. No.	Part No.	Part Name & Descriptions	
TR041, 042	2730253015	2SC2878(A)/(B)	TRANSISTOR
D001	2760049008	1S2076	DIODE
~004			
D005, 006	2760236031	HZ5C-1	ZENER
D007	2760049008	1S2076	DIODE
~010			
D011, 012	2760313019	HZ20-2	ZENER
D013	2760216019	KB-265	DIODE
~018			
RESISTORS (not included Carbon Film ±5%, 1/4W Type)			
ΔR001	2412314007	100 ohm ±5% 1/4W CARBON (NB)	
~004			
ΔR009, 010	2412314049	10 ohm ±5% 1/4W CARBON (NB)	
R039	2410210019	11 kohm ±5% 1/2W CARBON	
~042			
ΔR043	2412314010	390 ohm ±5% 1/4W CARBON (NB)	
~046			
ΔR047	2412314049	10 ohm ±5% 1/4W CARBON (NB)	
~050			
C051, 052	2410177000	470 ohm ±5% 1/2W CARBON	

Ref. No.	Part No.	Part Name & Descriptions	
R053, 054	2410161003	100 ohm ±5% 1/2W CARBON	
R055, 056	2420203003	10 Mohm ±10% 1/4W CARBON COMPOSIT	
ΔR061, 062	2412370054	10 kohm ±5% 1/4W CARBON (NB)	
ΔR063	2412314049	10 ohm ±5% 1/4W CARBON (NB)	
~066			
R067, 068	2440025009	47 ohm ±5% 1W METAL OXIDE (NB)	
R079	2412314023	470 ohm ±5% 1/4W CARBON (NB)	
R081	2412314023	470 ohm ±5% 1/4W CARBON (NB)	
R083, 084	2410184006	910 ohm ±5% 1/2W CARBON	
R085	2410210019	11 kohm ±5% 1/2W CARBON	
~088			
VR001, 002	2116016009	SEMI FIXED RESISTOR 100 ohm	
VR003, 004	2110409007	VARIABLE RESISTOR 100 kohm TONE	
VR005	2110407009	VARIABLE RESISTOR 250 kohm BALANCE	

Ref. No.	Part No.	Part Name & Descriptions	
CAPACITORS			
C001	2544146004	1μF	50V ELECTROLYTIC
~004			
C005, 006	2554121006	100pF	±5% 50V PLASTIC FILM
C007, 008	2554161008	0.0047μF	±5% 50V PLASTIC FILM
C009, 010	2554121006	100pF	±5% 50V PLASTIC FILM
C011, 012	2549011008	1μF	50V ELECTROLYTIC
C013	2521079071	22pF	±10% 500V MICA
~016			
C017, 018	2554121001	750pF	±5% 50V PLASTIC FILM
C019, 020	2551134041	0.047μF	±5% 50V PLASTIC FILM
C021, 022	2521081043	10pF	±0.5pF 500V MICA
C023	2544025002	10μF	25V ELECTROLYTIC
~026			
C027, 028	2544035005	10μF	35V ELECTROLYTIC
C029	2544038002	100μF	35V ELECTROLYTIC
C031	2544038002	100μF	35V ELECTROLYTIC
C033	2544041002	470μF	35V ELECTROLYTIC

ETC0699B SERVO UNIT

Ref. No.	Part No.	Part Name & Descriptions
C035	2544041002	470 μ F 35V ELECTROLYTIC
C037, 038	2521079039	47pF \pm 10% 500V MICA
C039, 040	2521061005	33pF \pm 10% 50V MICA
C041, 042	2551135079	0.012 μ F \pm 5% 50V PLASTIC FILM
C043, 044	2551140051	0.082 μ F \pm 5% 50V PLASTIC FILM
C045, 046	2521057006	15pF \pm 10% 50V MICA
C047, 048	2521065001	68pF \pm 10% 50V MICA
C049, 050	2551135079	0.012 μ F \pm 5% 50V PLASTIC FILM
C051, 052	2551134070	0.22 μ F \pm 5% 50V PLASTIC FILM
C053, 054	2544044009	1 μ F 50V ELECTROLYTIC
C055, 056	2554137003	470pF \pm 5% 50V PLASTIC FILM
C057, 058	2554149009	0.0015 μ F \pm 5% 50V PLASTIC FILM
C059, 060	2554137003	470pF \pm 5% 50V PLASTIC FILM
C059, 060	2554121006	100pF \pm 5% 50V PLASTIC FILM
C061 ~064	2544044009	1 μ F 50V ELECTROLYTIC
OTHER PARTS		
SW001	2220997001	P.W. BOARD
SW002	EP-5667H1	TERMINAL PIN USED 4
SW003	2090008146	JUMPER P=5mm USED 1
	2090008120	JUMPER P=10mm USED 21
	2090008104	JUMPER P=15mm USED 2
	2050141014	COMMON PLATE
	2050185038	3P WIRE HOLDER USED 14
	2050185041	4P WIRE HILDER USED 1
	2050185067	6P WIRE HOLDER
	2124467006	3P PUSH SWITCH LOW, HIGH, PRE
	2124447000	1P PUSH SWITCH DIRECT
	2120204001	ROTARY SWITCH PRESET
	4121502001	SW BRACKET (B)
	4700009006	PAN SCREW WITH S.W 3x6 USED 4
	2034213007	3P CONNECTOR CORD
	2034213010	3P CONNECTOR CORD
	2034213023	3P CONNECTOR CORD
	2036105074	4P CONNECTOR CORD
	2040090010	6P CONNECTOR CORD
	2034189063	3P CONNECTOR CORD
	2034217003	3P CONNECTOR CORD
	2034217016	3P CONNECTOR CORD
	2034213010	3P CONNECTOR CORD
	2034185012	3P CONNECTOR CORD

ETC0699B SERVO UNIT PARTS LIST

Ref. No.	Part No.	Part Name & Descriptions
SEMICONDUCTOR		
IC111	2630205008	NJM2041DD (JRC) IC
RESISTORS		
R131 ~134	2412123007	20 kohm \pm 5% 1/4W CARBON
R135, 136	2412116001	10 kohm \pm 5% 1/4W CARBON
R137, 138	2412124006	22 kohm \pm 5% 1/4W CARBON
CAPACITORS		
C071, 072	2561030012	1 μ F \pm 5% 100V METALIZED
C073, 074	2544132005	10 μ F 16V ELECTROLYTIC
C075, 076	2544089006	1 μ F \pm 20% 50V ELECTROLYTIC
OTHER PARTS		
	2221045004	P.W. BOARD
	2050122033	3P CONNECTOR PIN ASS'Y
	2050190036	3PNH CONNECTOR BASE

EUX0016B EQ. & MC UNIT PARTS LIST

Ref. No.	Part No.	Part Name & Descriptions	
SEMICONDUCTORS			
TR001 ~004	2730177007	2SC1626(Y)	TRANSISTOR
TR005 ~012	2750038045	2SK369(BL)/(GR)-C	FET
TR013, 014	2710170024	2SA1316(BL)/(GR)	TRANSISTOR
TR015, 016	2730187039	2SC2240(BL)/(GR)	TRANSISTOR
TR017, 018	2710168007	2SA1145(O/Y)	TRANSISTOR
TR019, 020	2730281003	2SC2705(O/Y)	TRANSISTOR
TR021, 022	2710168007	2SA1145(O/Y)	TRANSISTOR
TR023, 024	2730281003	2SC2705(O/Y)	TRANSISTOR
TR025 ~028	2730177007	2SC1626(Y)	TRANSISTOR
TR029 ~036	2750038045	2SK369(BL)/(GR)-C	FET
TR037, 038	2710170024	2SA1316(BL)/(GR)	TRANSISTOR
TR039, 040	2730187039	2SC2240(BL)/(GR)	TRANSISTOR
TR041, 042	2710168007	2SA1145(O/Y)	TRANSISTOR
TR043, 044	2730281003	2SC2705(O/Y)	TRANSISTOR
TR045, 046	2710168007	2SA1145(O/Y)	TRANSISTOR
TR047, 048	2730281003	2SC2705(O/Y)	TRANSISTOR
TR049 ~052	2730177007	2SC1626(Y)	TRANSISTOR
TR053 ~060	2750038045	2SK369(BL)/(GR)-C	FET
TR061, 062	2710170024	2SA1316(BL)/(GR)	TRANSISTOR
TR063, 064	2730187039	2SC2240(BL)/(GR)	TRANSISTOR
TR065, 066	2710168007	2SA1145(O/Y)	TRANSISTOR
TR067, 068	2730281003	2SC2705(O/Y)	TRANSISTOR
TR069, 070	2710168007	2SA1145(O/Y)	TRANSISTOR
TR071, 072	2730281003	2SC2705(O/Y)	TRANSISTOR
D001 ~008	2760049008	1S2076	DIODE
D009, 010	2760236031	HZ5C-1	ZENER
D011, 012	2760216019	KB-265	ZENER
D013 ~020	2760049008	1S2076	ZENER
D021, 022	2760236031	HZ5C-1	ZENER
D023, 024	2760216019	KB-265	DIODE
D025 ~032	2760049008	1S2076	DIODE
D033, 034	2760236031	HZ5C-1	ZENER
D035, 036	2760216019	KB-265	DIODE

Ref. No.	Part No.	Part Name & Descriptions	
D038 ~040	2760049008	1S2076	DIODE
RESISTORS (not included Carbon Film ±5%, 1/4W Type)			
R001, 002	2410225004	47 kohm	±5% 1/2W CARBON
R003, 004	2410137008	10 ohm	±5% 1/2W CARBON
AR009 ~012	2440048028	3.9 kohm	±5% 1W METAL OXIDE (NB)
AR013, 014	2442026093	2 kohm	±5% 2W METAL OXIDE (NB)
AR017 ~020	2412321045	220 ohm	±5% 1/4W CARBON (NB)
AR021, 022	2412314007	100 ohm	±5% 1/4W CARBON (NB)
R033, 034	2410140008	13 ohm	±5% 1/2W CARBON
AR037, 038	2412369078	4.7 kohm	±5% 1/2W CARBON (NB)
AR039, 040	2412321003	1 kohm	±5% 1/2W CARBON (NB)
AR041 ~044	2412321016	22 ohm	±5% 1/2W CARBON (NB)
R045, 046	2410177000	470 ohm	±5% 1/2W CARBON
AR047 ~050	2412314049	10 ohm	±5% 1/4W CARBON (NB)
AR059 ~062	2440048028	3.9 kohm	±5% 1W METAL OXIDE (NB)
AR063, 064	2442026093	2 kohm	±5% 2W METAL OXIDE (NB)
AR067 ~070	2412321045	220 ohm	±5% 1/4W CARBON (NB)
AR071, 072	2412314007	100 ohm	±5% 1/4W CARBON (NB)
R083, 084	2412319015	2.7 ohm	±5% 1/2W CARBON
AR087, 088	2412369078	4.7 kohm	±5% 1/4W CARBON (NB)
AR089, 090	2412321003	1 kohm	±5% 1/4W CARBON (NB)
AR091 ~094	2412321016	22 ohm	±5% 1/4W CARBON (NB)
R095, 096	2410177000	470 ohm	±5% 1/2W CARBON
AR097 ~100	2412314049	10 ohm	±5% 1/4W CARBON (NB)
R101, 102	2410161003	100 ohm	±5% 1/2W CARBON
R103, 104	2410225004	47 kohm	±5% 1/2W CARBON
R105, 106	2410157004	68 ohm	±5% 1/2W CARBON
AR111 ~114	2440048028	3.9 kohm	±5% 1W METAL OXIDE (NB)
AR115, 116	2442026093	2 kohm	±5% 2W METAL OXIDE (NB)
AR121 ~124	2412321045	220 ohm	±5% 1/4W CARBON (NB)
R133, 134	2410156005	62 ohm	±5% 1/2W CARBON
AR135, 136	2412314007	100 ohm	±5% 1/4W CARBON (NB)
AR139, 140	2412369078	4.7 kohm	±5% 1/4W CARBON (NB)

EUX0016B EQ & MC UNIT

Ref. No.	Part No.	Part Name & Descriptions
ΔR141, 142	2412321003	1 kohm ±5% 1/4W CARBON (NB)
ΔR143 ~146	2412321016	22 ohm ±5% 1/4W CARBON (NB)
R147, 148	2410177000	470 ohm ±5% 1/2W CARBON
ΔR149 ~152	2412314049	10 ohm ±5% 1/4W CARBON (NB)

CAPACITORS

C001, 002	2554121006	100pF ±5% 50V PLASTIC FILM
C003, 004	2549011037	4.7μF 50V LR ELECTROLYTIC
C005, 006	2554161008	0.0047μF ±5% 50V PLASTIC FILM
C007, 008	2521008000	8pF ±0.5pF 50V MICA
C009, 010	2544063006	100μF 80V ELECTROLYTIC
C011, 012	2521079071	22pF ±10% 500V MICA
C013, 014	2544060009	10μF 100V ELECTROLYTIC
C015, 016	2544060025	1μF 100V ELECTROLYTIC
C017, 018	2554139001	560pF ±5% 50V PLASTIC FILM
C019, ~022	2544060012	100μF 100V ELECTROLYTIC
C023	2544044009	1μF 50V ELECTROLYTIC
C025	2544044009	1μF 50V ELECTROLYTIC
C027, 028	2554121006	100pF ±5% 50V PLASTIC FILM
C029, 030	2544063006	100μF 80V ELECTROLYTIC
C031, 032	2554151005	0.0018μF 50V PLASTIC FILM
C033, 034	2549011024	10μF 50V ELECTROLYTIC
C035, 036	2521008000	8pF ±5pF 50V MICA
C037, 038	2521079071	22pF ±10% 500V MICA
C039, 040	2544060009	10μF 100V ELECTROLYTIC
C041, 042	2544060025	1μF 100V ELECTROLYTIC
C043, 044	2554139001	560pF ±5% 50V PLASTIC FILM
C045, ~048	2544060012	100μF 100V ELECTROLYTIC
C049	2544044009	1μF 50V ELECTROLYTIC
C051, 052	2554121006	100pF ±5% 50V PLASTIC FILM
C053, 054	2544063006	100μF 80V ELECTROLYTIC
C055, 056	2549011037	4.7μF 50V LR ELECTROLYTIC
C057, 058	2554151005	0.018μF ±5% 50V PLASTIC FILM
C059, 060	2521008000	8pF ±0.5pF 50V MICA
C061, 062	2521079071	22pF ±10% 500V MICA
C063, 064	2544060009	10μF 100V ELECTROLYTIC

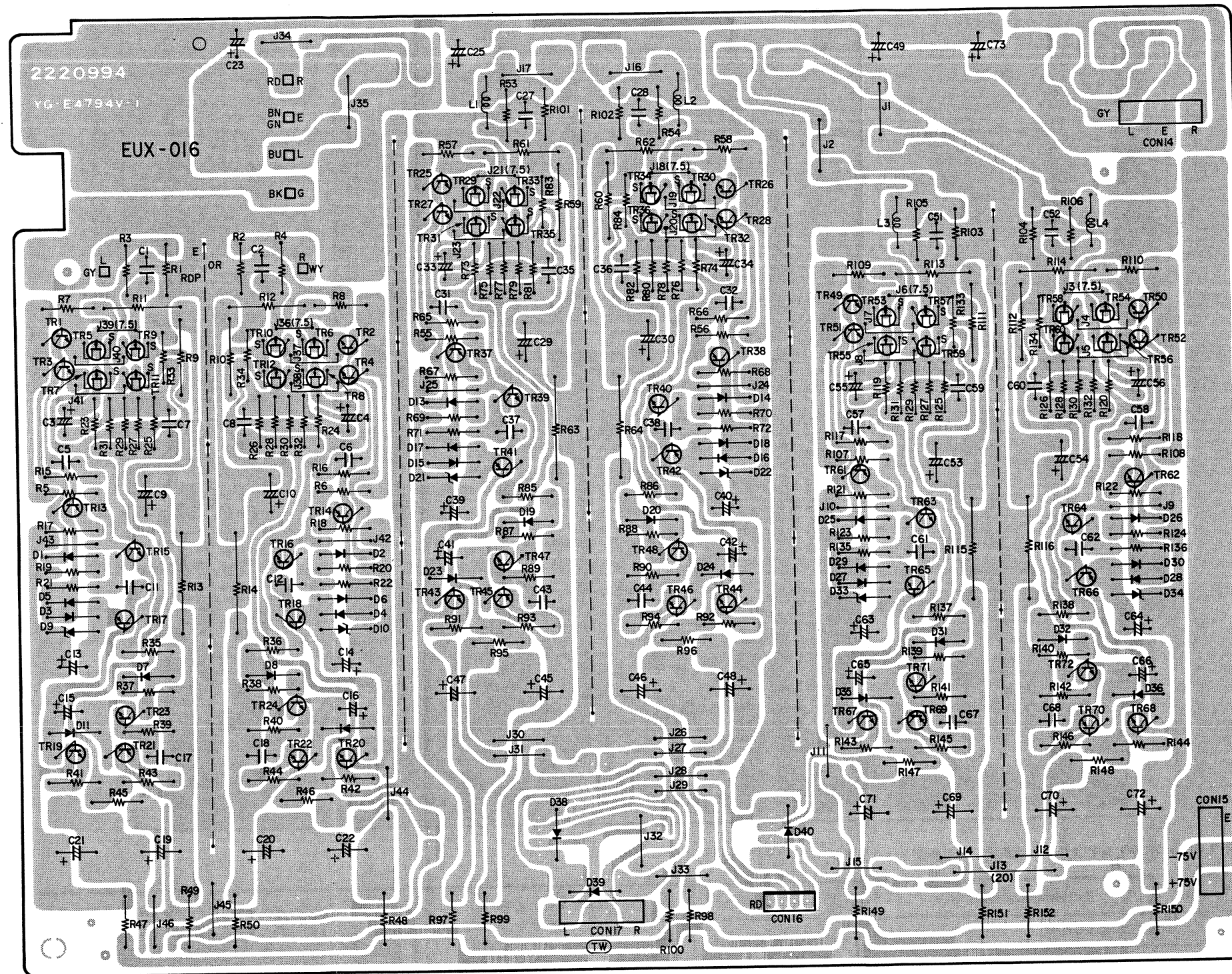

Ref. No.	Part No.	Part Name & Descriptions
C065, 066	2544060025	1μF 100V ELECTROLYTIC
C067, 068	2554139001	560pF ±5% 50V PLASTIC FILM
C069, ~072	2544060012	100μF 100V ELECTROLYTIC
C073	2544044009	1μF 50V ELECTROLYTIC
C075, 076	2554151005	0.0082μF ±5% 50V PLASTIC FILM

Ref. No.	Part No.	Part Name & Descriptions
OTHER PARTS		
	2220994004	P.W. BOARD
	EP-5667H1	TERMINAL PIN USED 10
	2090008133	JUMPER P=7.5mm USED 6
	2090008120	JUMPER P=10mm USED 41
	2090008162	JUMPER P=20mm USED 1
	2050122033	3P CONNECTOR PIN ASS'Y USED 3
	2050190049	4PNH CONNECTOR BASE

Ref. No.	Part No.	Part Name & Descriptions
L003, 004	2050184000	2P CONNECTOR BASE USED 3
	2050145007	4P CONNECTOR BASE
	2050141027	COMMON PLATE USED 5
RL001	2140036000	REED RELAY
~003	2030226027	1P CONTACT ASS'Y

ETC0653B TAPE & FLAT UNIT

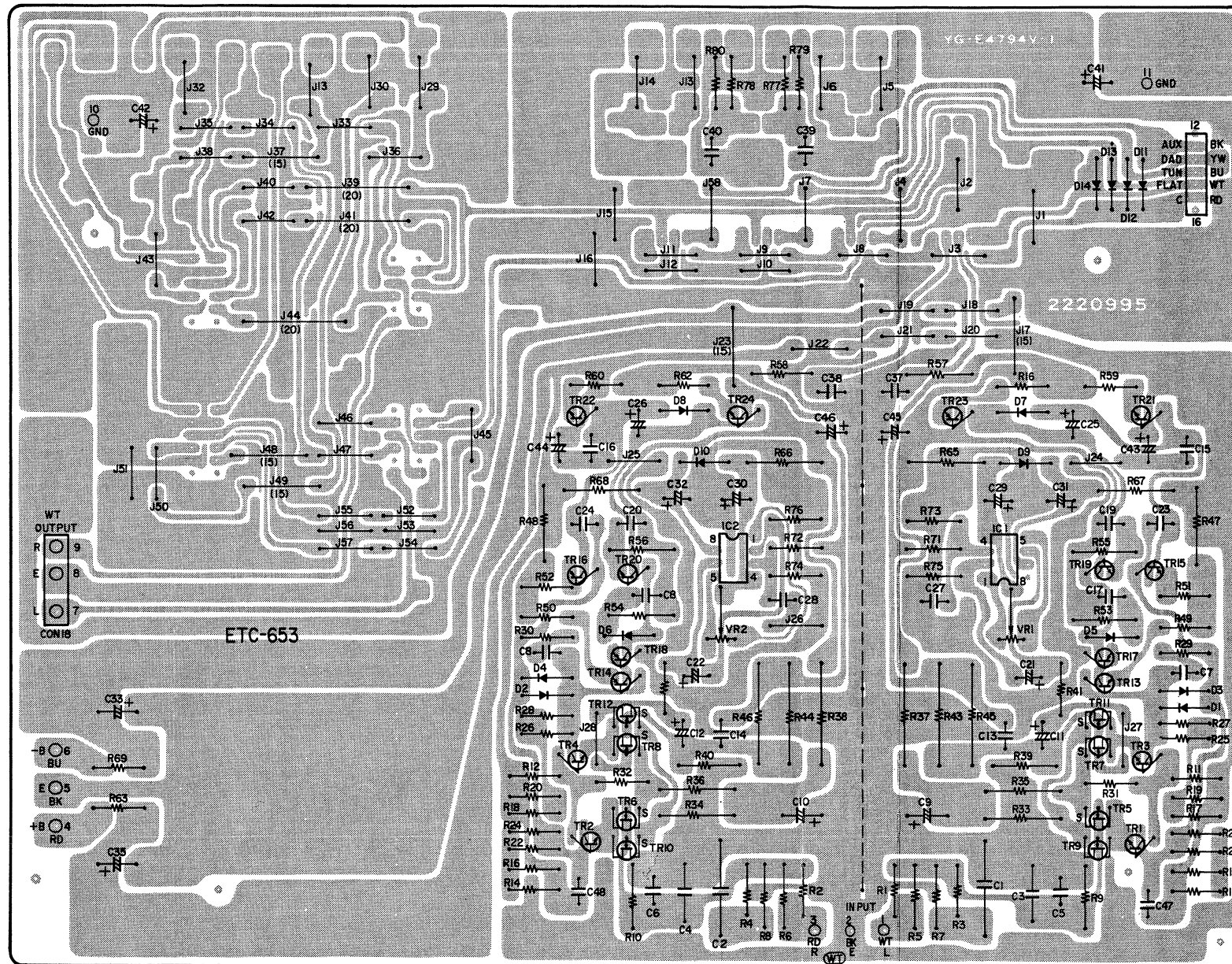

ETC0653B TAPE & FLAT UNIT PARTS LIST

Ref. No.	Part No.	Part Name & Descriptions
SEMICONDUCTORS		
IC001, 002	2630133002	μPC741C (NEC) IC
TR001 ~004	2730281003	2SC2705(O/Y) TRANSISTOR
TR005 ~012	2750038045	2SK369(BL)/(GR)-C FET
TR013 ~018	2710168007	2SA1145(O/Y) TRANSISTOR
TR019, 020	2730281003	2SC2705(O/Y) TRANSISTOR
TR021, 022	2730199001	2SC2238(Y) TRANSISTOR
TR023, 024	2710104003	2SA968(Y) TRANSISTOR
D001 ~006	2760049008	1S2076 DIODE

Ref. No.	Part No.	Part Name & Descriptions
D007, 008	2760216019	KB-265 DIODE
D009, 010	2760224001	HZ-30 ZENER
D011 ~014	2760049008	1S2076 DIODE
RESISTORS (not included Carbon Film ±5%, 1/4W Type)		
R001, 002	2412318029	4.7 kohm ±2% 1/4W CARBON
R003, 004	2412320059	680 ohm ±2% 1/4W CARBON
R005, 006	2410224005	43 kohm ±5% 1/2W CARBON
R007, 008	2410220009	30 kohm ±5% 1/2W CARBON
R009, 010	2410257001	1 Mohm ±5% 1/2W CARBON

Ref. No.	Part No.	Part Name & Descriptions
ΔR033 ~036	2440048028	3.9 kohm ±5% 1W METAL OXIDE (NB)
ΔR037, 038	2442026093	2 kohm ±5% 2W METAL OXIDE (NB)
ΔR039, 040	2442025052	51 ohm ±5% 1W METAL OXIDE (NB)
ΔR043 ~046	2440098023	1 kohm ±5% 2W METAL OXIDE (NB)
ΔR047, 048	2440046020	2.7 kohm ±5% 1W METAL OXIDE (NB)
ΔR049 ~052	2412314049	10 ohm ±5% 1/4W CARBON (NB)
R053 ~056	2410203000	5.6 kohm ±5% 1/2W CARBON
R057, 058	2410177000	470 ohm ±5% 1/2W CARBON
ΔR059 ~062	2440017020	10 ohm ±5% 1W METAL OXIDE (NB)
ΔR063	2412314049	10 ohm ±5% 1/4W CARBON (NB)

Ref. No.	Part No.	Part Name & Descriptions
ΔR065 ~068	2440053026	10 kohm ±5% 1W METAL OXIDE (NB)
ΔR069	2412314049	10 ohm ±5% 1/4W CARBON (NB)
VR001, 002	2116016054	SEMI FIXED RESISTOR 50 kohm
CAPACITORS		
C001, 002	2554083021	0.47μF ±2% 100V PLASTIC FILM
C003, 004	2554196057	0.15μF ±1% 200V PLASTIC FILM
C005, 006	2551134025	0.01μF ±5% 50V PLASTIC FILM
C007, 008	2554155001	0.0027μF ±5% 50V PLASTIC FILM
C009, 010	2544063006	100μF 80V ELECTROLYTIC
C011, 012	2549011011	2.2μF 50V ELECTROLYTIC
C015, 016	2521079097	220pF ±10% 500V MICA
C017, 018	2554137003	470pF ±5% 50V PLASTIC FILM
C019, 020	2554133007	330pF ±5% 50V PLASTIC FILM
C021, 022	2544069000	22μF 10V ELECTROLYTIC
C023, 024	2521081043	10pF ±0.5pF 500V MICA
C025, 026	2544060025	1μF 100V ELECTROLYTIC
C027, 028	2551134025	0.01μF ±5% 50V PLASTIC FILM
C029 ~032	2544060009	10μF 100V ELECTROLYTIC
C033	2544060012	100μF 100V ELECTROLYTIC
C035	2544060012	100μF 100V ELECTROLYTIC
C037, 038	2554129008	220pF ±5% 50V PLASTIC FILM
C041, 042	2544044009	1μF 50V ELECTROLYTIC
C043 ~046	2544060025	1μF 100V ELECTROLYTIC
C047, 048	2554155001	0.0027μF ±5% 50V PLASTIC FILM
OTHER PARTS		
SW001, 002	2124366000	SLIDE SW (REMOTE)
RL001 ~004	2140036000	REED RELAY
	2220995003	P.W. BOARD
	EP-5667H1	TERMINAL PIN USED 4
	2090008120	JUMPER P=10mm USED 52
	2090008104	JUMPER P=15mm USED 5
	2090008162	JUMPER P=20mm USED 3
	2050141027	COMMON PLATE
	2050184000	2P CONNECTOR BASE
	2050145007	4P CONNECTOR BASE USED 3
	2050122033	3P CONNECTOR PIN ASS'Y
	2050185054	5P WIRE HOLDER
	2038109094	5P CONNECTOR CORD
	2030226027	1P CONTACT ASS'Y USED 2
	2030226043	1P CONTACT ASS'Y
	2034166031	3P CONNECTOR CORD
	2034177004	3P CONNECTOR CORD
	2038109094	5P CONNECTOR CORD

ETC0654B DIGITAL UNIT PARTS LIST

Ref. No.	Part No.	Part Name & Descriptions	
SEMICONDUCTORS			
IC001	2620337009	TC9135P (TOSHIBA)	IC
IC002	2620300007	HD14011BP (HITACHI)	IC
IC003	2620438005	M54565P (MITSUBISHI)	IC
IC004	2630299001	NJM78M24A (JRC)	IC
TR003	2730198015	2SC1815(BL)	TRANSISTOR
TR008, 009	2710102005	2SA1015(Y)	TRANSISTOR
TR010	2730198015	2SC1815(BL)	TRANSISTOR
TR012	2710102005	2SA1015(Y)	TRANSISTOR
TR013	2750043014	2SK381(C)/(D)	FET
TR014	2720058000	2SB834(Y)	TRANSISTOR
TR015	2740065044	2SD880(Y)/(GR)	TRANSISTOR
TR016	2750043014	2SK381(C)/(D)	FET
TR017	2730198015	2SC1815(BL)	TRANSISTOR
TR020	2710102005	2SA1015(Y)	TRANSISTOR
TR021, 022	2730198015	2SC1815(BL)	TRANSISTOR
D008	2760049008	1S2076	DIODE
~013			
D014	2760236031	HZ5C-1	ZENER
D015	2760049008	1S2076	DIODE
~018			
D020	2760333002	UB-152LFA	DIODE
D021	2760348000	S2K20F	DIODE
D022	2760318001	HZ12A-2	ZENER
D024	3939091006	TLY206 (YELLOW)	LED
D028, 029	2760049008	1S2076	DIODE
D031, 032	2760049008	1S2076	DIODE
RESISTORS (not included Carbon ±5%, 1/4W Type)			
R039	2420199007	4.7 Mohm ±10% 1/4W CARBON COMPOSIT	
R045	2412321032	4.7 ohm ±5% 1/4W CARBON COMPOSIT	
R047	2412321032	4.7 ohm ±5% 1/4W CARBON COMPOSIT	
R049	2412321032	4.7 ohm ±5% 1/4W CARBON COMPOSIT	
VR001	2110408008	VARIABLE RESISTOR 68 kohm FOR MAIN	
CAPACITORS			
C002	2544132005	10µF 16V ELECTROLYTIC	
C003, 004	2544145005	0.47µF 50V ELECTROLYTIC	
C005	2544129005	47µF 10V ELECTROLYTIC	
C006	2544127007	220µF 6.3V ELECTROLYTIC	
C007	2544133004	22µF 16V ELECTROLYTIC	
C009	2551134070	0.22µF ±5% 50V PLASTIC FILM	
C010	2561016007	0.068µF ±10% 500V METALIZED	
C011	2544035005	10µF 35V ELECTROLYTIC	
C012, 013	2544042001	100µF 35V ELECTROLYTIC	
C014	2544035005	10µF 35V ELECTROLYTIC	
C015	2554121006	100pF ±5% 50V PLASTIC FILM	
C016	2544146004	1µF 50V ELECTROLYTIC	
C017, 018	2544141009	10µF 35V ELECTROLYTIC	
C020	2544132005	10µF 16V ELECTROLYTIC	
~026			

ETC0654B DIGITAL UNIT

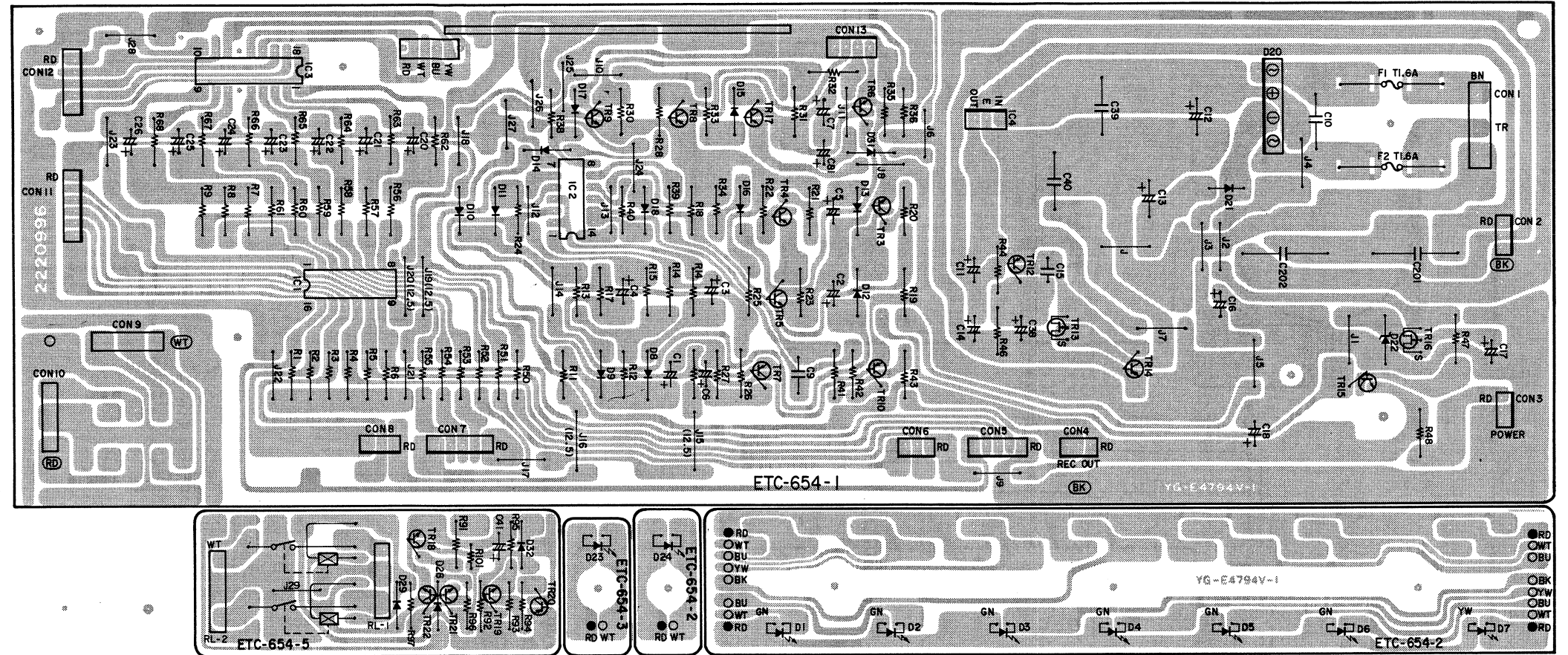

Ref. No.	Part No.	Part Name & Descriptions	
C038	2544044009	1µF	50V ELECTROLYTIC
C041	2544132005	10µF	16V ELECTROLYTIC
C081	2544044009	1µF	50V ELECTROLYTIC
C203	2544132005	10µF	16V ELECTROLYTIC
OTHER PARTS			
SW001 ~007	2220996206	P.W. BOARD	
	EP-5667H1	TERMINAL PIN USED 4	
	2090008120	JUMPER WIRE P=10mm USED 26	
	2090008117	JUMPER WIRE P=12.5mm USED 4	
	2124361005	PUSH SWITCH USED 7	
	2050122033	3P CONNECTOR PIN ASS'Y USED 5	
	2050133035	3P NH CONNECTOR BASE USED 6	
	2050190049	4P NH CONNECTOR BASE	

Ref. No.	Part No.	Part Name & Descriptions	
F003, 004	2050133051	5P NH CONNECTOR BASE USED 3	
	2050133064	6P NH CONNECTOR BASE	
	2050185041	4P WIRE HOLDER	
	2050185054	5P WIRE HOLDER USED 2	
	2061035054	FUSE 1.6A(T) USED 2	
RL001, 002	2020014003	FUSE CLIP USED 4	
	2140036000	REED RELAY USED 2	
	2034213010	3P CONNECTOR CORD	
	2050161078	CONNECTOR BASE	
	4170197111	HEAT SINK	
	4700010008	PAN SCREW WITH S.W.W 3x8	
	4730354019	TAPPING SCREW (2) 3x8	
	2030226027	1P CONTACT ASS'Y	
	2034185041	3P CONNECTOR CORD	

Ref. No.	Part No.	Part Name & Descriptions	
	2034214006	3P CONNECTOR CORD	
	2034203033	3P CONNECTOR CORD USED 2	
	2036102006	4P CONNECTOR CORD	
	2038109081	5P CONNECTOR CORD USED 2	

CONNECTION DIAGRAM

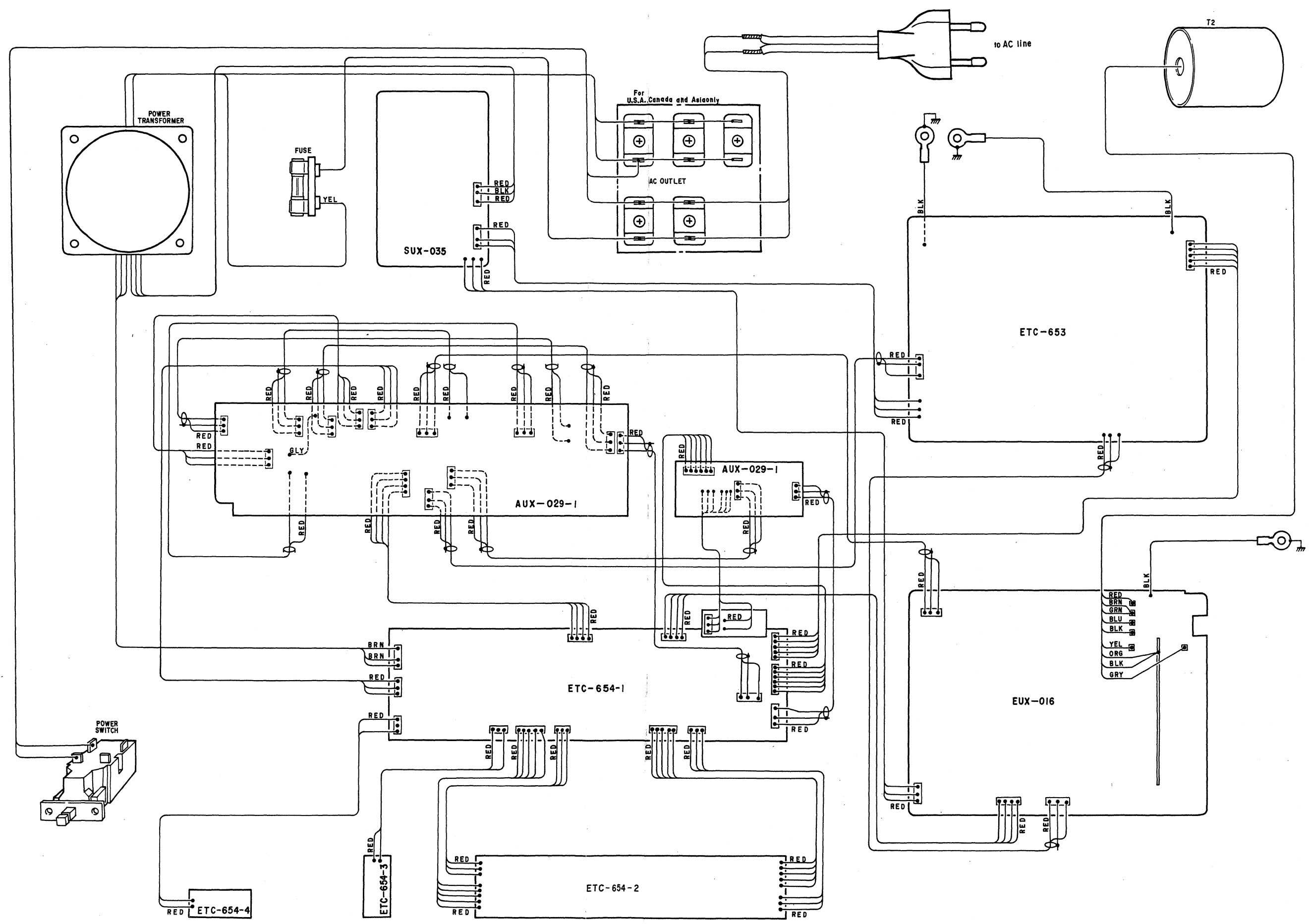

⚠ Means important safety item, which must be replaced, when necessary, by a part specified or meeting the specification by the manufacturer.

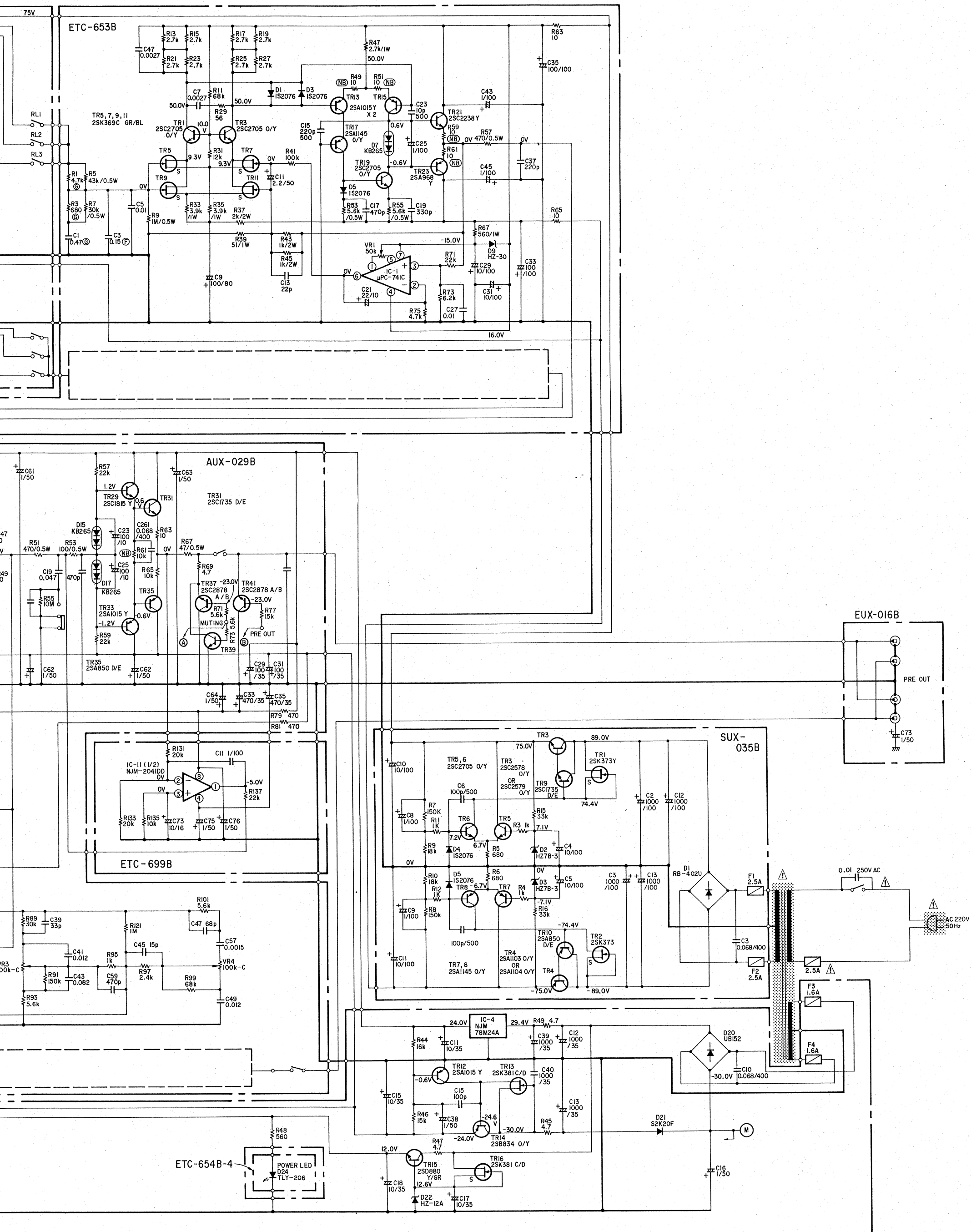

NOTES:
 ALL RESISTANCE VALUES IN OHM, K = 1,000 OHM, M = 1,000,000 OHM.
 ALL CAPACITANCE VALUES IN MICROFARAD, P = MICRO-MICRO FARAD.
 EVERY VOLTAGES AND CURRENTS IS MEASURED AT NO SIGNAL INPUT CONDITION.
 CIRCUIT AND PARTS ARE SUBJECT TO CHANGE WITHOUT PRIOR NOTICE.

EXPLODED VIEW OF CHASSIS AND CABINET

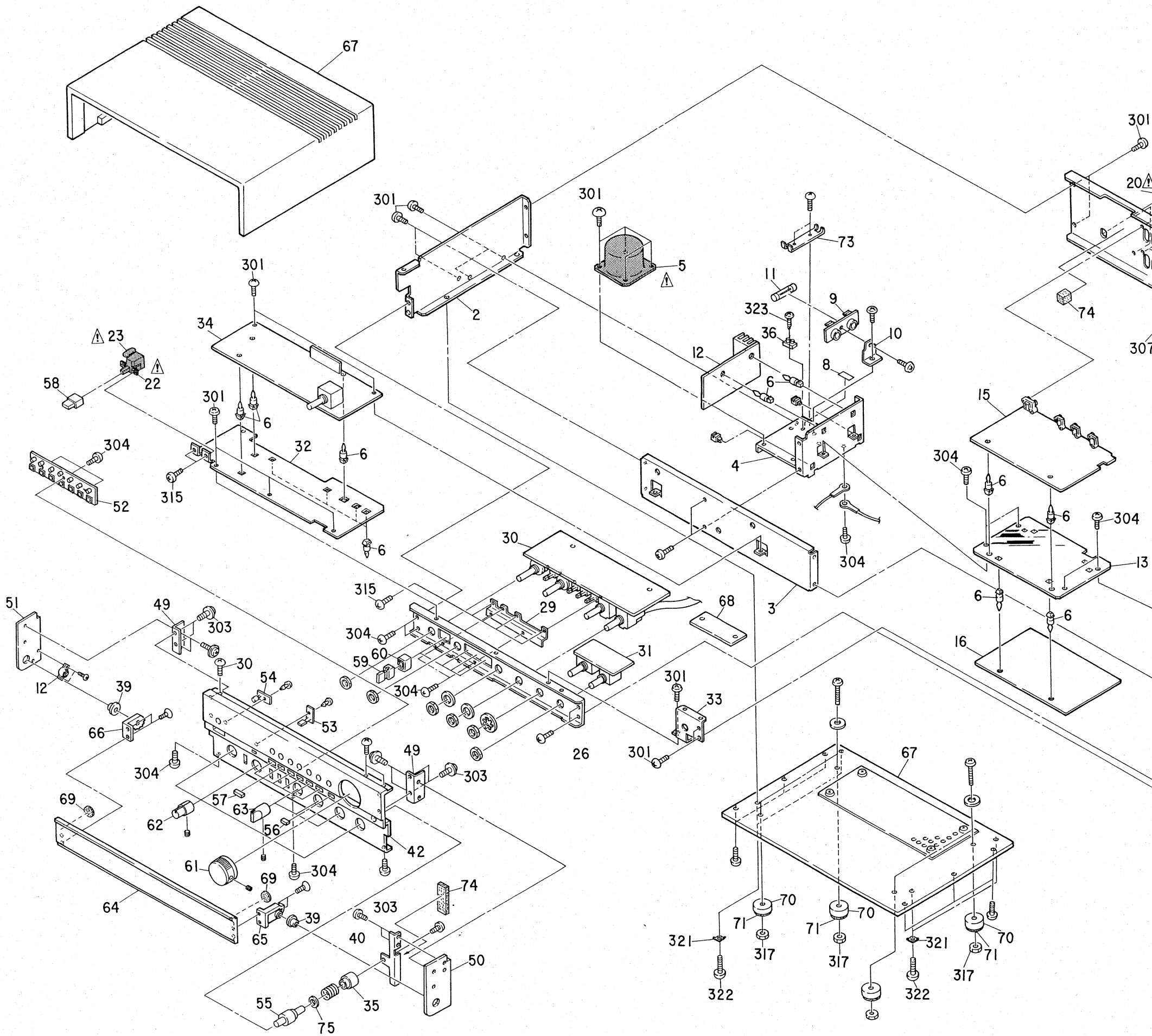

EXPLODED VIEW OF CHASSIS AND CABINET

Ref. No.	Part No.	Part Name & Descriptions	Q'ty
1	4110403001	SIDE CHASSIS (R)	1
2	4110404000	SIDE CHASSIS (L)	1
3	4110405009	CENTER CHASSIS	1
4	4110406011	TRANS CHASSIS	1
▲ 5	2334506003	POWER TRANS	1
6	MD-5271	P.C.B. SUPPORT	13
7	-	-	-
8	5130654017	FUSE LABEL	1
▲ 9	202011006	FUSE HOLDER	1
10	4120238101	BRACKET	1
▲ 11	2061025077	FUSE TLC2.5A	1
12	SUX0035B	P. SUPPLY UNIT	1s
13	4121499004	SHIELD PLATE	1
14	4610121029	CUSHION	12
15	EUX0016B	EQ. & MC UNIT	1s
16	ETC0653B	TAPE & FLAT UNIT	1s
17	1059017001	BACK PANEL	1
18	-	-	-
▲ 19	2062026101	AC CORD	1
▲ 20	4450020005	CORD BUSH	1
21	2050043109	GND TERMINAL	1
▲ 22	2124049068	POWER SWITCH	1
▲ 23	2568023006	CAPACITOR 0.01μF/250VAC	1
24	2320070006	MC TRANS ASS'Y	1

Ref. No.	Part No.	Part Name & Descriptions	Q'ty
25	4121500003	BRACKET	1
26	4110408006	FRONT CHASSIS (B)	1
27	2120207011	ROTARY REMOTE (A) SW	1
28	2120208007	ROTARY REMOTE (B) SW	1
29	-	-	-
30	AUX0029B-1	CONTROL UNIT	1s
31	AUX0029B-2	BALANCE UNIT	1s
32	4140333002	SHIELD BRACKET	1
33	4110407104	FRONT CHASSIS	1
34	ETC0654B-1	VR/DIG UNIT	1s
35	4430303205	BOSS	1
36	2050086001	2P TERMINAL BLOCK	-
37	-	-	-
*38	4450033005	WIRE CLAMP BAND	23
39	4250140101	BEARING	1
40	4630370106	SPRING PLATE	1
41	-	-	-
42	1441160100	FRONT PANEL	1
43	1441161002	LED RING	1
44	1140078001	KNOB GUIDE (A)	1
45	1140079000	KNOB GUIDE (B)	1
46	1140080002	KNOB GUIDE (C)	1
47	1140081001	KNOB GUIDE (D)	1
48	1460647002	LED HOLDER (B)	1

Ref. No.	Part No.	Part Name & Descriptions	Q'ty
49	4121503000	BRACKET	1
50	1441162001	SIDE PLATE (R)	1
51	1441163000	SIDE PLATE (L)	1
52	ETC0654B-2	INPUT UNIT	1s
53	ETC0654B-4	PREOUT UNIT	1s
54	ETC0654B-3	POWER LED UNIT	1s
55	1130516104	PUSH KNOB (DOOR)	1
56	1130517006	PUSH KNOB (MUTING)	1
57	1130518005	PUSH KNOB (INPUT)	6
58	1130519004	PUSH KNOB ASS'Y (POWER)	1
59	1130520006	PUSH KNOB ASS'Y (TONE)	4
60	1140056007	FLEXIBLE RING	4
61	1120438001	KNOB ASS'Y (VR)	1
62	1120439000	KNOB ASS'Y (TONE)	3
63	1120440002	KNOB ASS'Y (TAPE)	3
64	1441165008	DOOR	1
65	4010139103	HINGE (R)	1
66	4010140105	HINGE (L)	1
67	1011534001	CABINET ASS'Y	1
68	ETC0699B	SERVO UNIT	1s
69	1220039009	SPACER	3
70	1441164009	FOOT BASE	4
71	1240038019	FELT SHEET	4
72	5130716023	FTX LEVEL	-

⚠ Means important safety item, which must be replaced, when necessary, by a part specified or meeting the specification by the manufacturer.

DENON

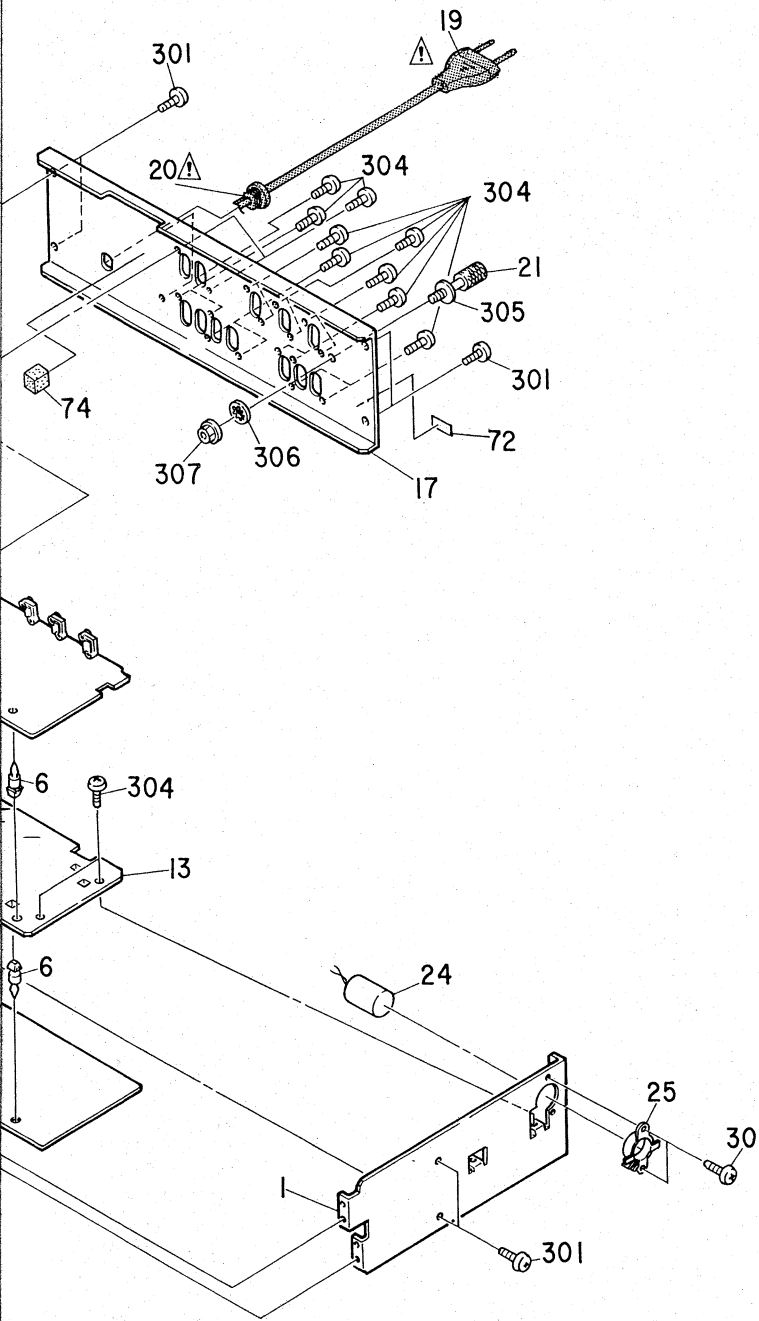

NIPPON COLUMBIA CO., LTD.

No. 14-14, 4-CHOME AKASAKA,
MINATO-KU, TOKYO 107 JAPAN
TEL: 03-584-8111
TLX: JAPANOLA J22591
CABLE: NIPPONCOLUMBIA TOKYO

Ref. No.	Part No.	Part Name & Descriptions	Q'ty
1	73	BASE BRACKET (L)	1
1	74	—	—
1	75	WASHER	1
1s	76	2P TERMINAL BLOCK	1
1s	77	INSULATING SHEET (B)	1
1s	78	RUBBER SHEET	1
1	79	RUBBER SHEET	1
1	80	RUBBER SHEET	3
6	81	RUBBER SHEET	4
1	82	RUBBER SHEET	1
4	83	MINI DAMPER	1
4	84	KNOB GUIDE	1
1	85	SPRING	1
3	86	BRACKET	1
3	87	STOPPER	1
1	88	PUSH RIVET	2
1	89	—	—
1	—	—	—
1	—	—	—
1s	—	—	—
3	—	—	—
4	—	—	—
4	—	—	—
—	—	—	—

Ref. No.	Part No.	Part Name & Descriptions	Q'ty
SCREWS, NUTS & WASHERS			Q'ty
301	4770064107	FIXING SCREW	42
302	4734454038	TAPPING SCREW (2) TRUS 4x8	4
303	4700009006	PAN SCREW WITH S.W 3x6	3
304	4730354035	TAPPING SCREW (2) 3x8 BLACK	13
305	4770088002	WASHER φ4.1 (NI)	1
306	4753100004	TOOTH WASHER φ4 (NI)	1
307	4756114000	NUT-WASHER M4	1
308	—	—	—
309	—	M8 NUT (SP)	2
310	—	M9 NUT (SP)	1
311	—	φ9 WASHER	1
312	4753005002	TOOTH WASHER φ8	1
313	4730354019	TAPPING SCREW (2) 3x8	3
314	4770195005	WASHER	2
315	—	—	—
316	—	—	—
317	—	—	—
318	—	—	—
319	4711301010	PAN SCREW 3x4	10
320	4700009022	PAN SCREW WITH S.W 3x6	1
321	WA-07411	WASHER	4
322	4700023008	PAN SCREW WITH S.W 4x20	4

Ref. No.	Part No.	Part Name & Descriptions	Q'ty
323	4730358015	TAPPING SCREW (2) 3x14	1
324	4730353036	TAPPING SCREW (2) 3x6 BLACK	4
325	4713102013	SCREW 2x5	2
326	4712302050	FLAT HEAD SCREW 3x5 (Ni)	4
327	—	—	—
PACKING & ACCESSORIES			Q'ty
a.	5040063060	STYLEN PAPER	1
b.	5040055007	CABINET SHEET	1
c.	5030411101	CUSHION (A)	1
d.	5030412003	CUSHION (B)	1
e.	5010924032	CARBON CASE	1
f.	5050061007	ENVELOPE	1
g.	2090012006	SHORT PIN	4
h.	5050076005	POLY COVER	1
i.	5119118008	INST. MANUAL	1
j.	5119119007	INST. MANUAL (B)	1
k.	2048121004	2P PIN CORD	1
l.	—	—	—